

BACKFLOW PREVENTION ASSEMBLY INSTALLATION GUIDE

REDUCED PRESSURE ASSEMBLY (RP)

This insert serves as a guidance document for the installation of backflow prevention assemblies within the Charleston Water System (CWS) service area. All installations must be inspected and approved by CWS. Contact CWS within two days of installation to request an inspection.

- Install assembly on customer's side of the water meter prior to any branch, tee or service connection.
- Install assembly in accordance with manufacturer's recommendations.
- Assembly must be installed above ground.
- Installed assembly shall be easily accessible for in-line maintenance and testing.
- Provide minimum 12" maximum 36" clearance between relief valve vent and finished grade.
- Provide minimum 6" clearance on all sides of the assembly, including test cocks.
- Relief valve vent shall never become submerged.
- No material shall obstruct the relief valve opening preventing venting to the atmosphere.
- For interior installations where water exiting the relief valve vent is required to be channeled to the atmosphere or to a floor drain, provide relief valve drain funnel with approved air gap.
- Provide minimum 2' of copper, bronze, or ductile iron piping on inlet and outlet side of assembly.
- Black iron, black steel or galvanized steel pipe shall not be used in the upstream piping.
- Installed assembly shall be rigid and stable. CWS reserves the right to require additional support and restraint.
- If an above-ground enclosure is used, provide minimum 6" clearance on all sides and two drain holes, equal in size to the relief valve vent opening, at the base of the enclosure.
- CWS highly recommends freeze protection, such as insulated enclosures or padded wraps, for all above ground assemblies.
- For assemblies exposed to vehicular traffic, protective bollards are recommended.

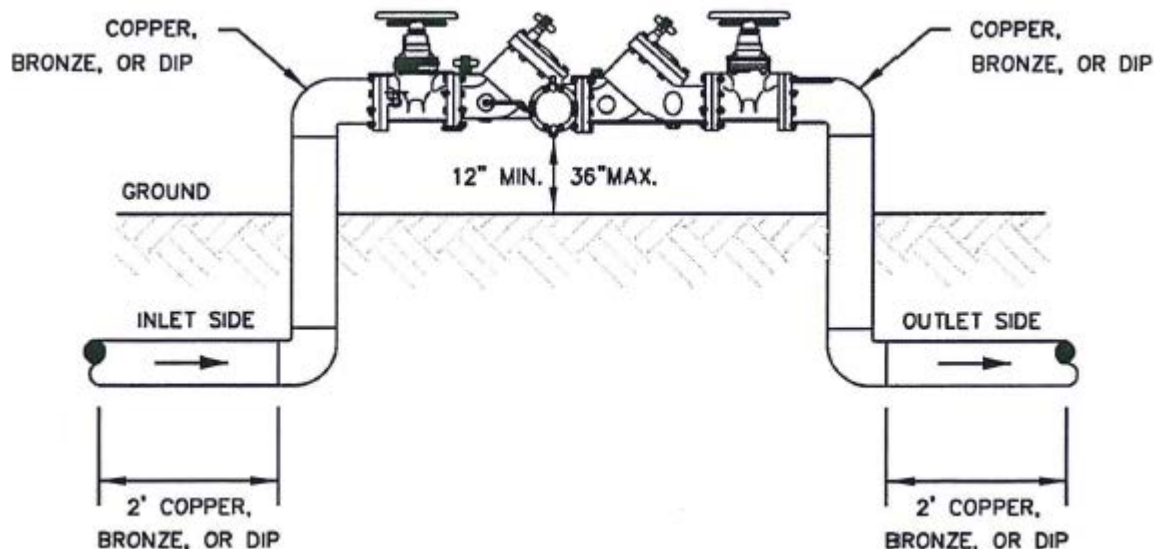

For questions concerning the installation, placement of your assembly or to request an inspection, contact CWS by phone at 843-727-6981, by fax at 843-579-6852, or by email at backflow@charlestoncpw.com. For additional information on CWS's Cross-Connection Control Program and a complete list of approved testers, please visit our website at www.charlestonwater.com.